

Digital Data in the Humanities

Lewis Lancaster

Electronic Cultural Atlas Initiative

University of California, Berkeley

www.ecai.org

•National Digital Archives Program (NDAP)

•National Science Council

•Phase 1, 2002~2006

•Phase 2, 2007~2011

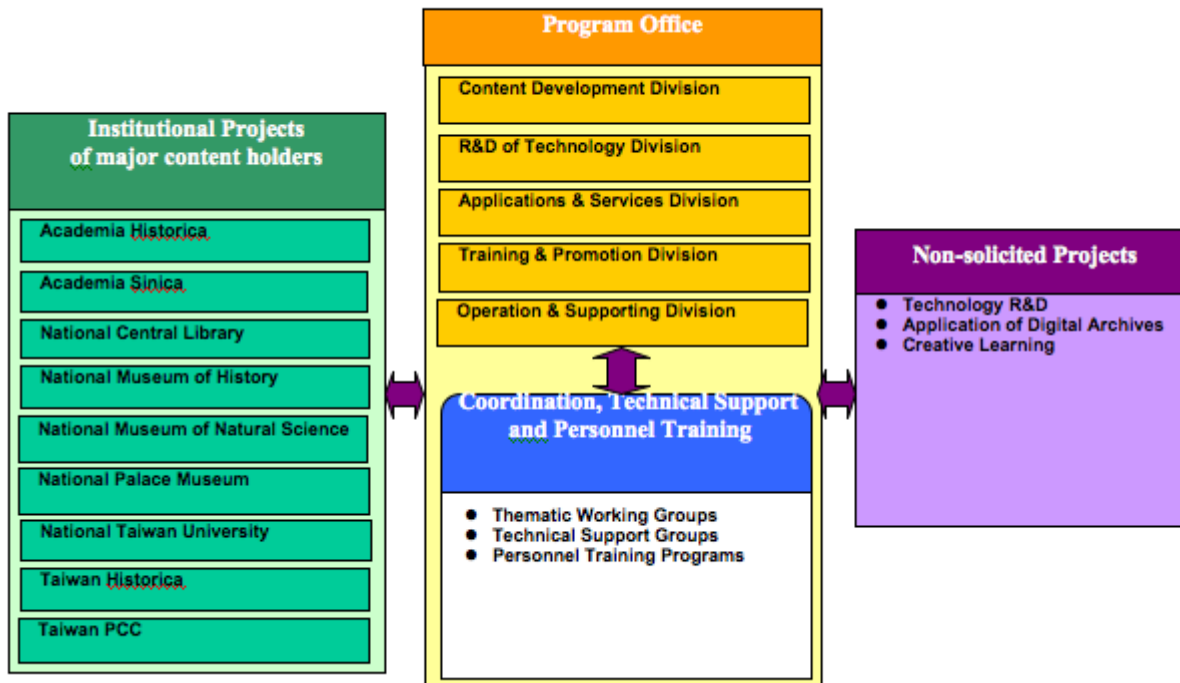

National Digital Archive Program Data Diversity

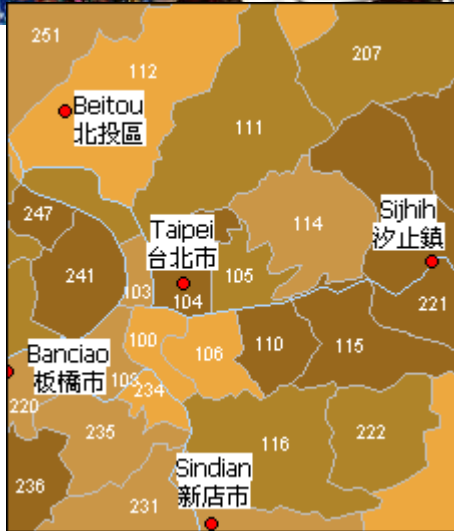
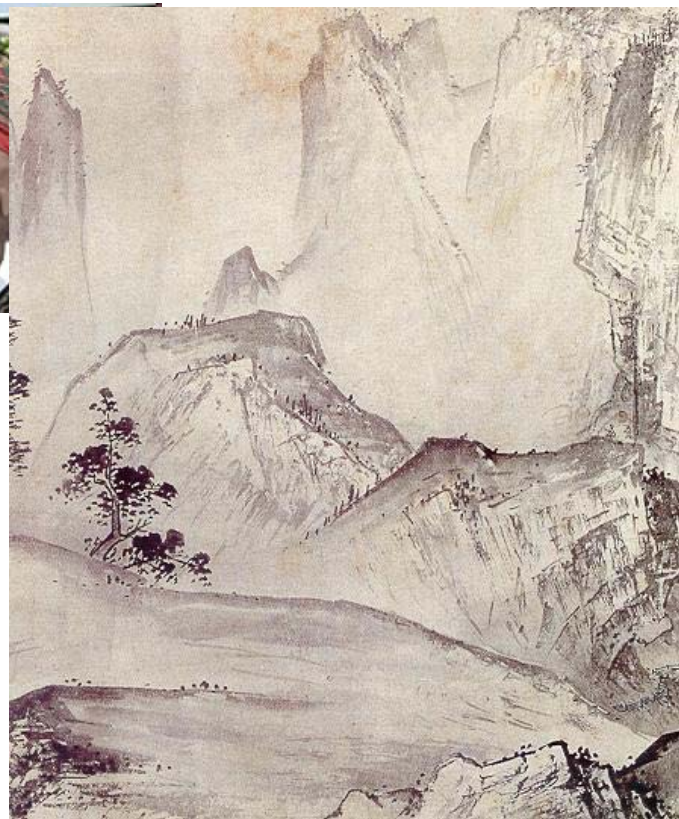



**Silo Effect:
Lack of coding
standards**



**Silo Effect:
No local preservation
strategy**

臺中市全市彩色空照照片圖



N
W E
S
比例尺：1/17000

AG&G 亞新圖土科技

閃爍
號出
變的年
許只

是暫時找不到出口吧了...，相信這個世代的全世界年輕人都有所同感。

一個十分豐富有維卻沈重的題材，以懸疑偵探為電影主架構，除了吸引年輕人的認同外，加上我們擅長街頭紀實的拍攝手法以及記錄式劇情片的真實感動敘事風格，相信它的話題可以擴展到更多不同的年齡層。就如同我們影片的宣传標語所說的：「捷運可以載你到西門町六號出口，但你的出口在哪裡？」讓我們一起來尋找出口吧！



Preserving data from many sources

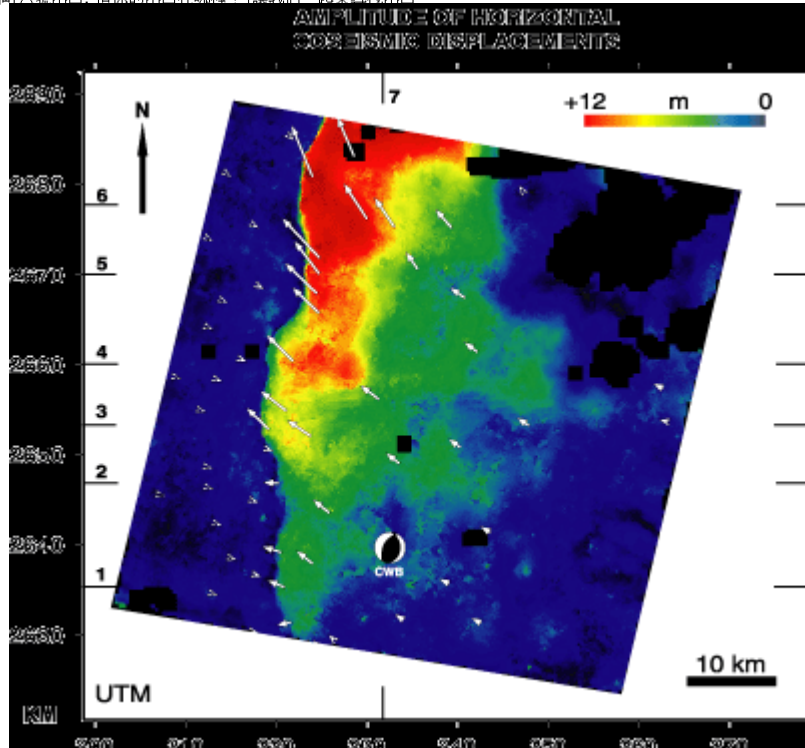

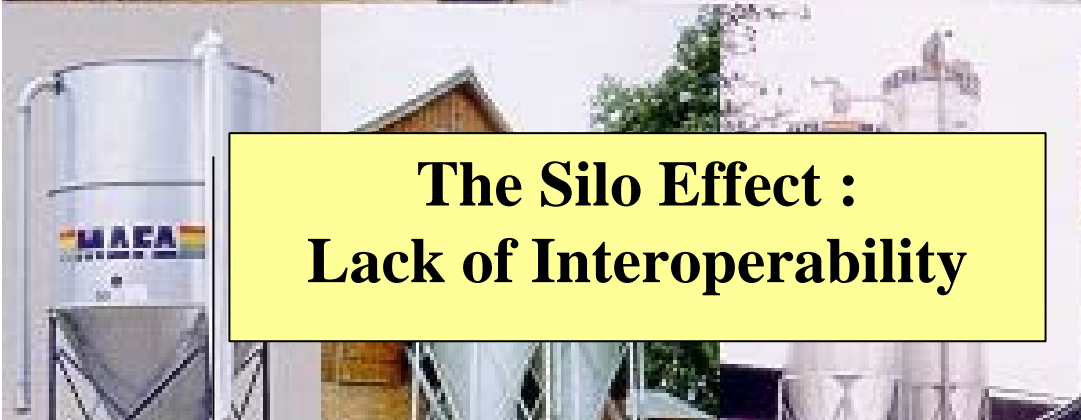
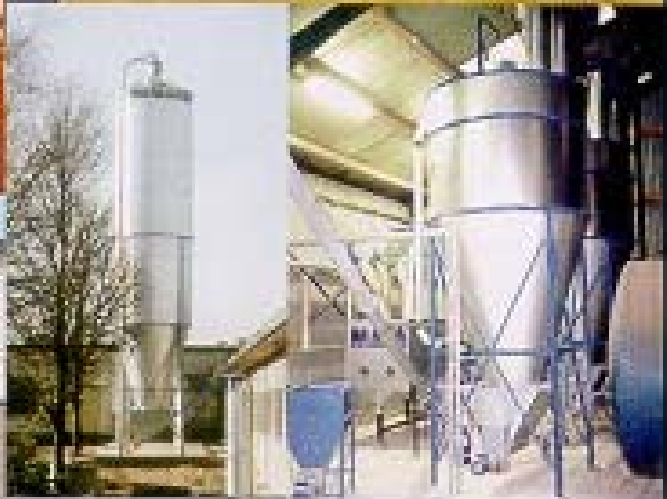

**The Silo Effect :
Lack of Interoperability**



Codex
System

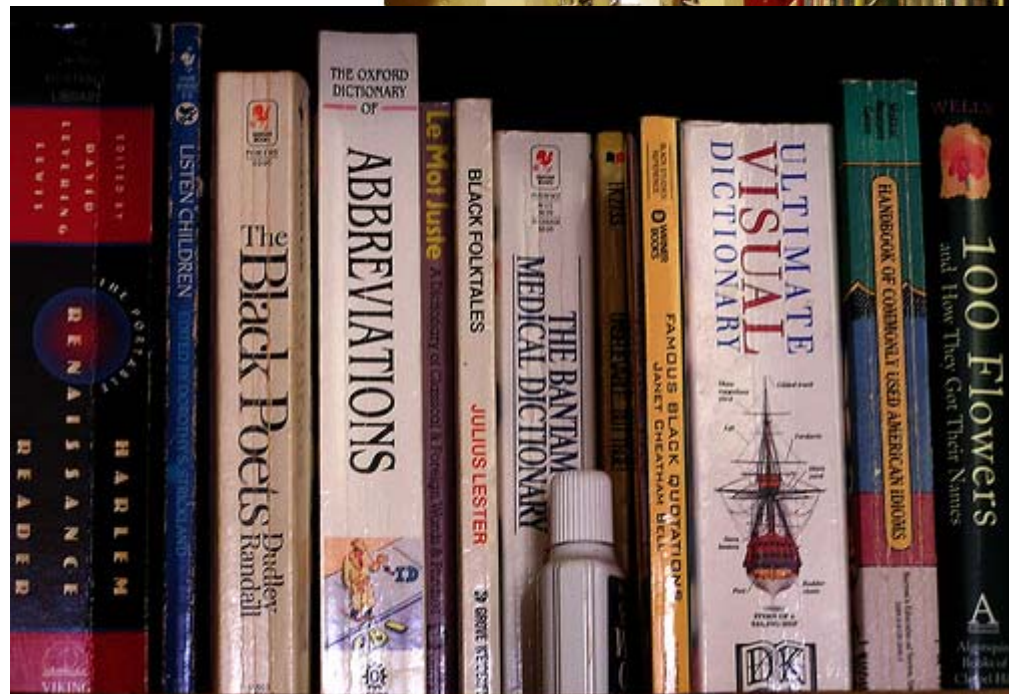

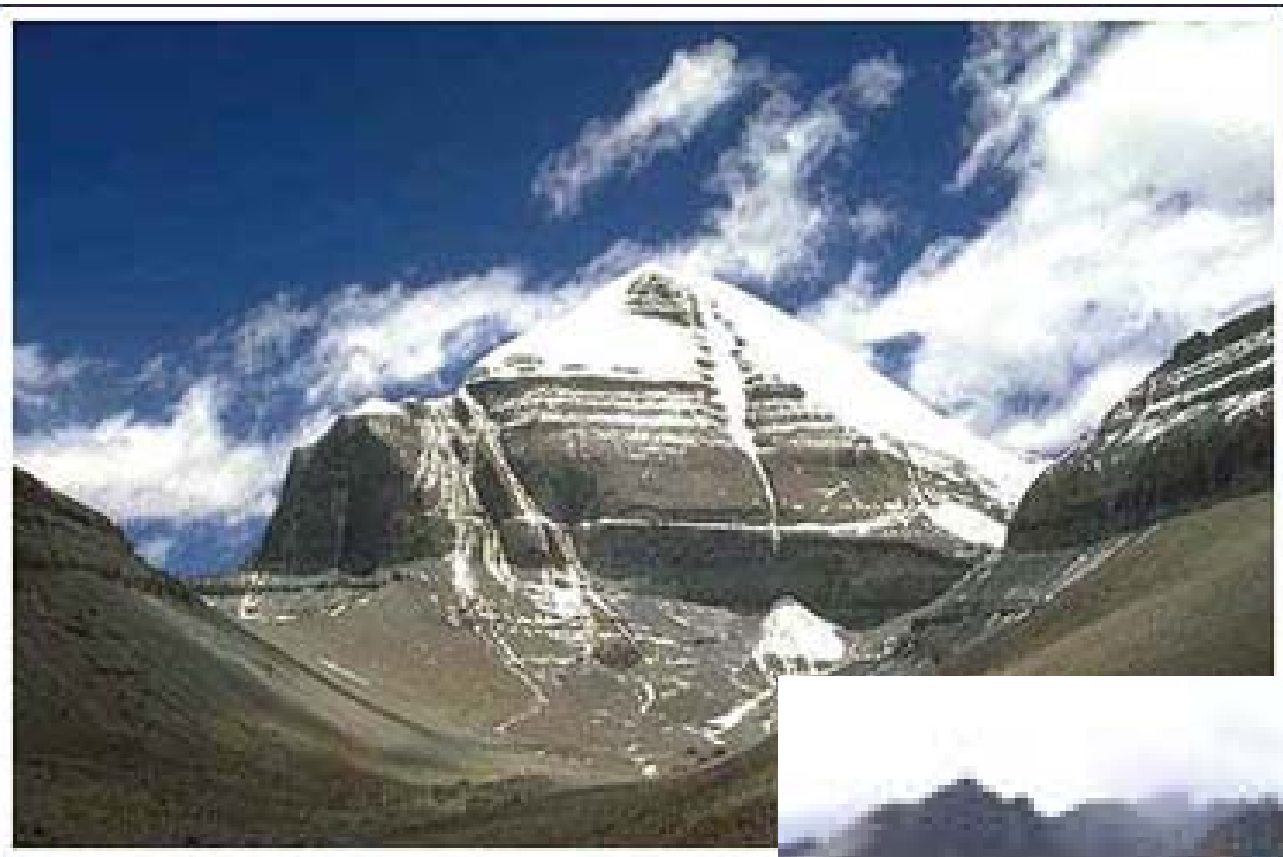

Reference service as
guide to overcome
obstacles

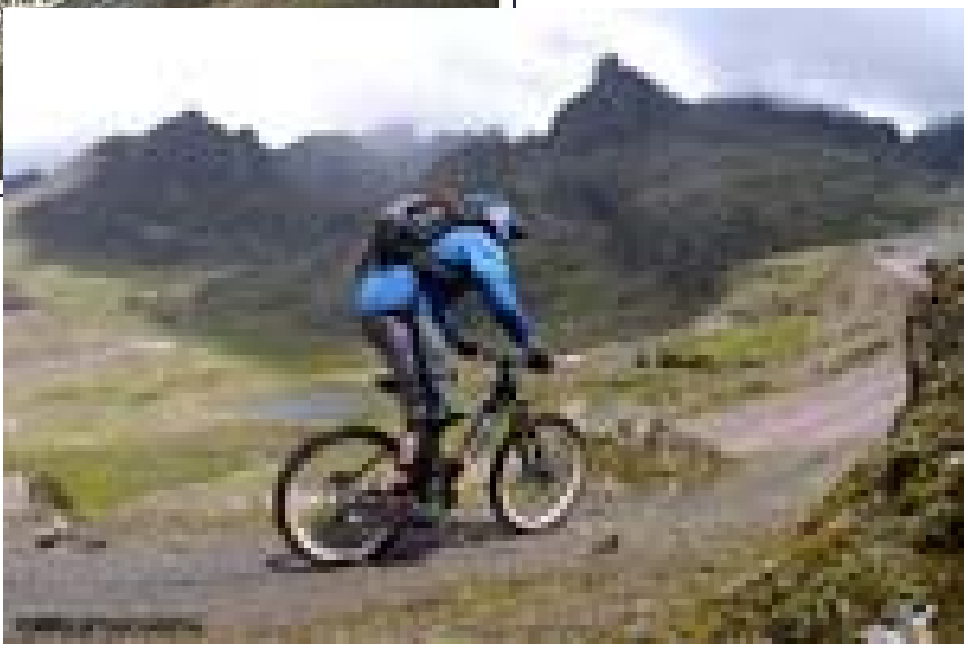

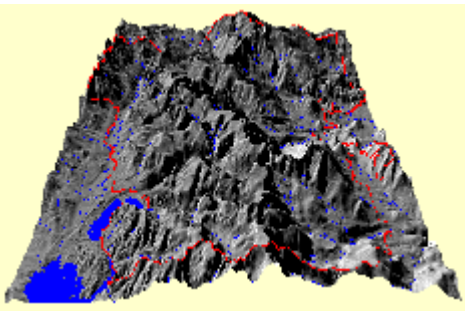

Barriers or perspectives?

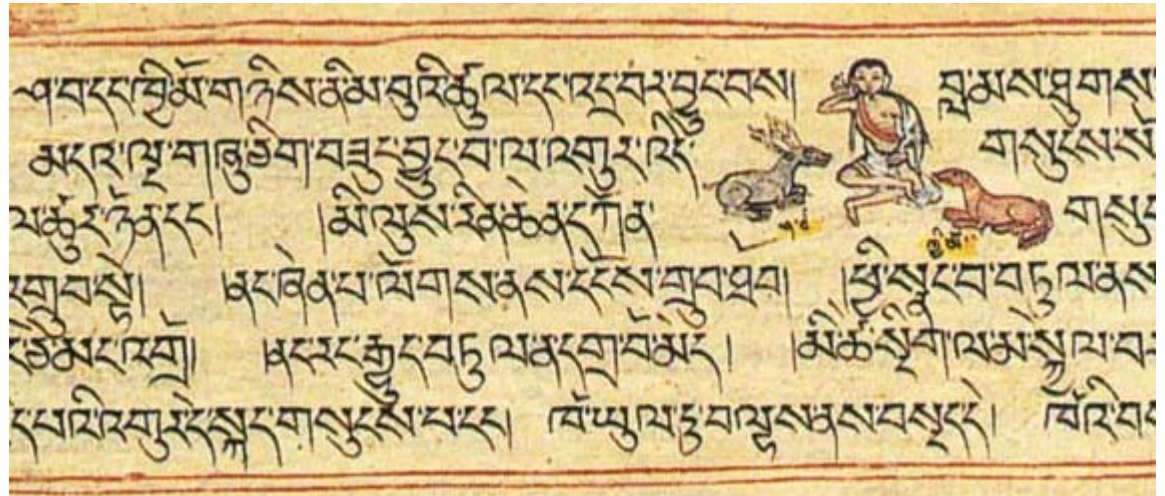

Constructing a
digital library





capstone of a
pyramid is called
"pyramidion"



Reconstructing a digital library from the “rubble” of the previous one

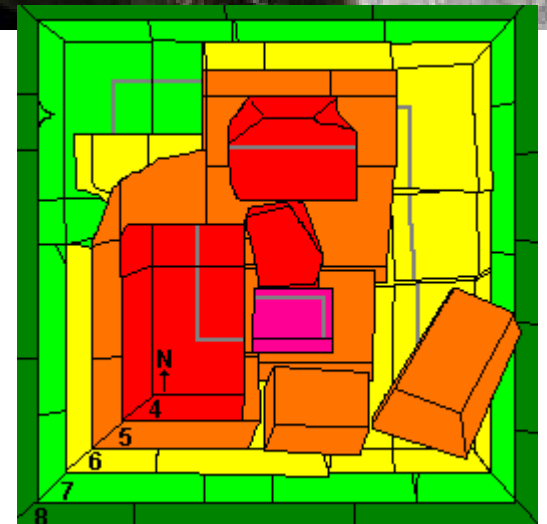
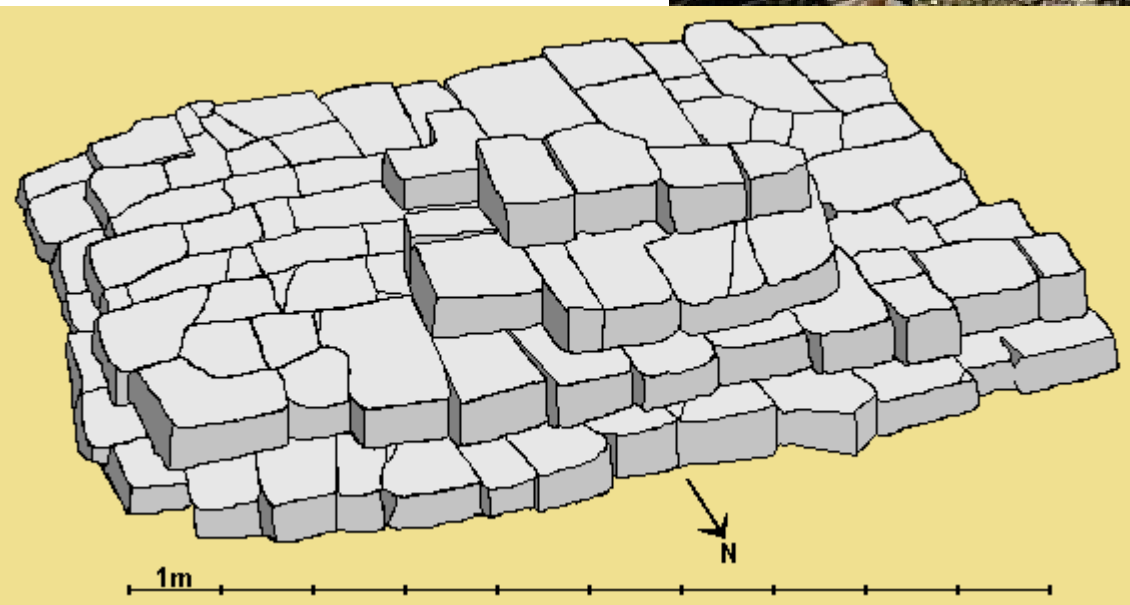



Browse by:

- Religion
- Place
- Time
- People
- Map

About:

- Collaborators
- Technology
- Sources
- User Guide

Collaboration WorkSpace

TimeMap™
time-based interactive mapping

Startup extent

Theme

- Buddhist sites** 
- Christian sites** 
- Islamic sites** 
- Jewish sites** 
- Tributary Rivers of China (ACASIAN)**
- Municipal and Prefectural Boundaries of China (Modern -- ACASIAN)**
- Lights of Earth NASA Image**
- Worldwide 1km DEM**



Map navigation controls: zoom in, zoom out, pan, home, layers, help.

Layer Opacity: 100% 0%

Maps

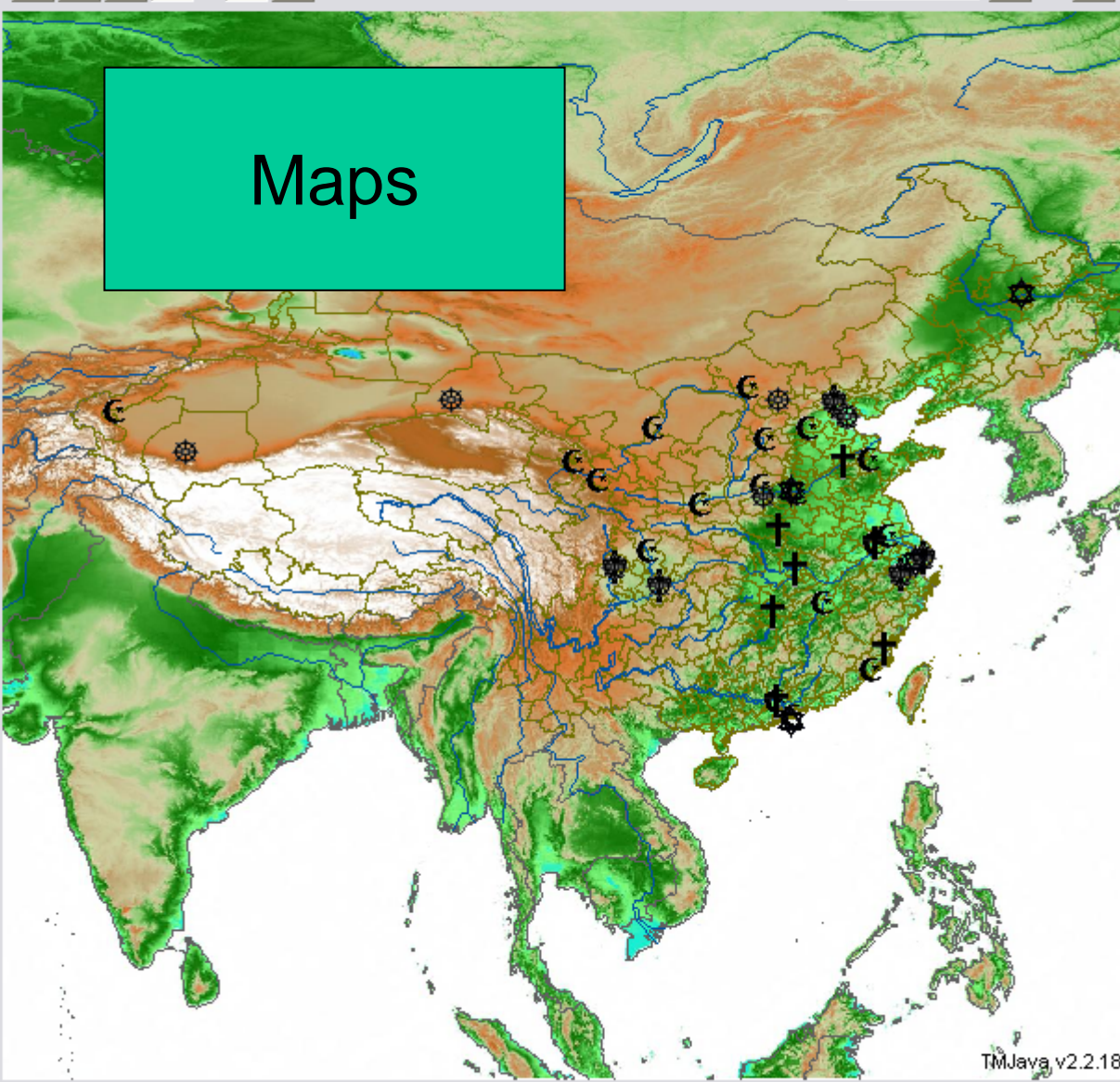

Search in the Cheshire LC Subject Authority file and Library of Congress catalog (powered by the [Cheshire II search engine](#))

Your search, encoded as *lcid sh 85024035*, was submitted to the *Cheshire LC Subject Authority file and Library of Congress catalog server*, **156** items were retrieved.

Resource Symbol Key:  Wikipedia search for subject or person

1. [Choson wangjo sillok. Selections.](#) Choson wangjo sillok chung ui Kija saryo / Sim Paek-kang p_yon. Soul-si : Minjok Munhwa Yon_guwon, 2002. 461 p. ; 30 cm.

Notes: Text in Korean (Hanmun) and Korean.

Subjects:

[Korea -- History -- To 935.](#) 

[China -- History -- Zhou dynasty, 1122-221 B.C.](#) 

[Jizi, -- 12th cent. B. C. -- Sources.](#) 

[Manchuria \(China\) -- History.](#) 

Other Authors: [Sim, Paek-kang.](#)

LC Call Number: DS911.25 .C475 2002

2. [Shu jing.](#) Le Chou-king, un des livres sacrés des Chinois, qui renferme les fondements de leur ancienne histoire, les principes de leur gouvernement & de leur morale; ouvrage recueilli par Confucius. Traduit & enrichi de notes, par feu le p. Gaubil ... Rev. & cor. sur le texte chinois, accompagné de nouvelles notes, de planches gravées en taille-douce & d'additions tirées des historiens originaux, dans lesquelles on donne l'histoire des princes omis dans le Chou-king. Par m. de Guignes ... On y a joint un Discours préliminaire, qui contient des recherches sur les tems antérieurs à ceux dont parle le Chou-king, & une notice de l'Y-king, autre livre sacré des Chinois. Paris, N. M. Tilliard, 1770. 2 p. l., cxliv, 474, [2] p. IV pl. 26 x 21 cm.

Notes: "Discours préliminaire, ou Recherches sur les tems antérieurs à ceux dont parle le Chou-king, & sur la mythologie chinoise, par le P. de Premare": p. [xliv]-cxxxviiij. "Notice du livre chinois nommé Y-king, ou Livre canonique des changemens, avec des notes, par M.

Linking vocabularies WHAT, WHERE, WHEN

WHAT

Library subject headings

Topic – Geographic subdivision – Chronological subdivision

WHERE

Place name gazetteer:

Place name – Type – Spatial markers (Lat & long) – When

WHEN

Time Period Directory

Period name – Type – Time markers (Calendar) – Where

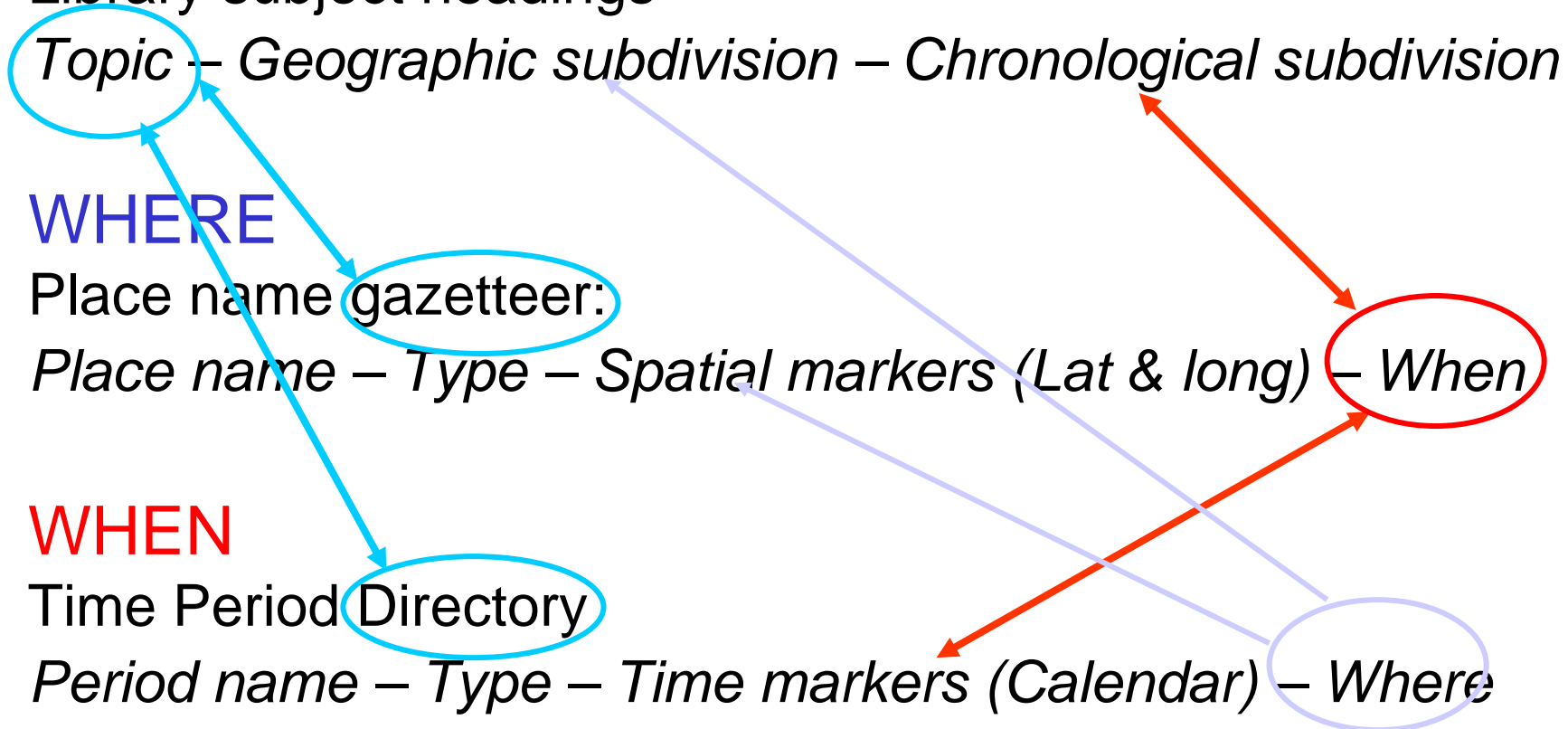

Named Time Periods
used by participants in the
2nd International Workshop
on Virtual Reality and Archaeology
CNR, Rome 2006

- B.C. ;A.D.;Prehistory; Roman; Medieval Age; Calabrian History; Greek-Hellenistic; Byzantine; Norman; Bronze Age; Hellenistic Period; Etruscan; Hallstat Period; Early Iron Age; 16th century; 1930s; 1940s; Inka imperial; Ancient; Historical; Pre-Islamic; IXth century; Grand Duchy of Tuscany; Crusades; Middle Ages; 2nd millennium B.C.; Present day; British conquest of Acadia; Janapadas; Pre-Buddhist; Mycenaean; Christmas; Late Pleistocene; BP; 18 ka BP; Bronze-Iron Age; 1972; Warring States Period; November 2005; Parthian; Historic Wall of Pontevedra; Three millennia; ancient Near East; past 3300 years; destruction of Amana; Amarna Period; Late Roman Period; "Modern"; post Later Roman Period; Last Glacial Maximum; fifth millennium B.C.; Roman colonization; ancient inhabited Poseidon-Paestrum; ancient town; Viking Age; early Middle Ages; ancient man; Quaternary age; five Ice Ages; prehispanic cultural history; ancient Middle America; past 4000 years; Khmer Empire; Neolithic onwards; turn of the 13th and 14th centuries; early Modern Period; 600 year tree ring chronology; later Social Darwinism; Western; since more than 100 years; Late Antiquity; Late Classic Maya; ancient Maya; Middle Horizon; Early Colonial Period; Liangzhu culture; Maya culture; Prehistory to late Medieval; Longobard invasion; first century A.D.; first century B.C.; autumn 2005; Ancient Boeotia; Prehistoric culture of the Delmarva Peninsula; Middle Bronze Age; Post-Early Byzantine ; beginning of 2004; Late Roman Period; Romanization Period; contemporary era; Northern Wei Dynasty; Ming Dynasty; Yangtze River Culture; 5000 year civilization; beginning of 19th century; ancient city wall; Chimu Culture; Roman Age; republic age; Severian age; ancient footpaths; Arenal phase; Precolumbia phases; Trondora phase; earliest Clovis horizon; Spanish conquest; Inka Empire; premodern; end of 2nd century AD; Hadrianic or Antonine (Roman) period; Nabataean; Late Cambrian; ancient settlement; Venetian Republic; Late Holocene; Roman epochs; Jurassic; Cenozoic events; Qatabanian; medieval setting; current social phenomena; ancient human transformation; World War II; present day;

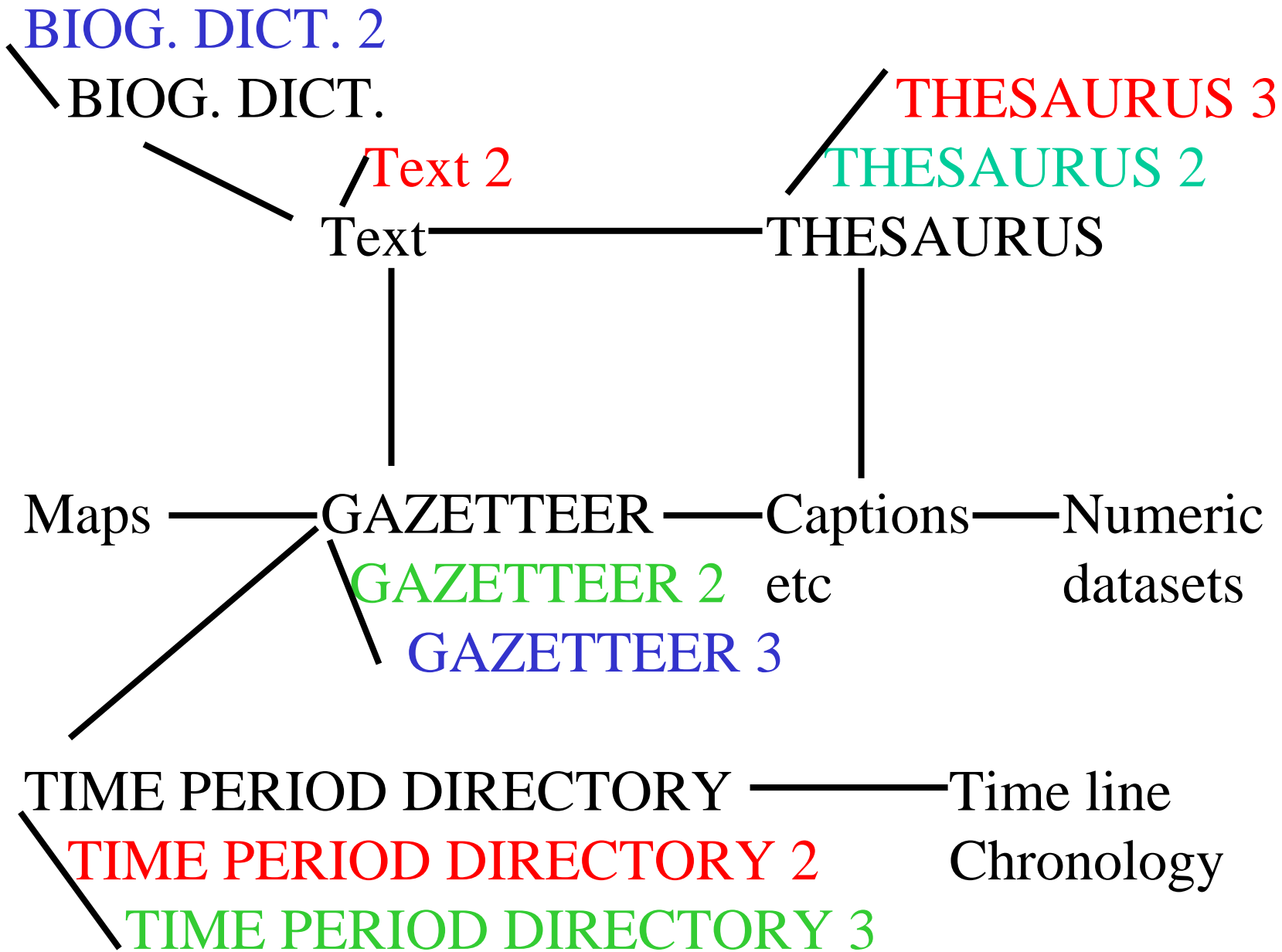

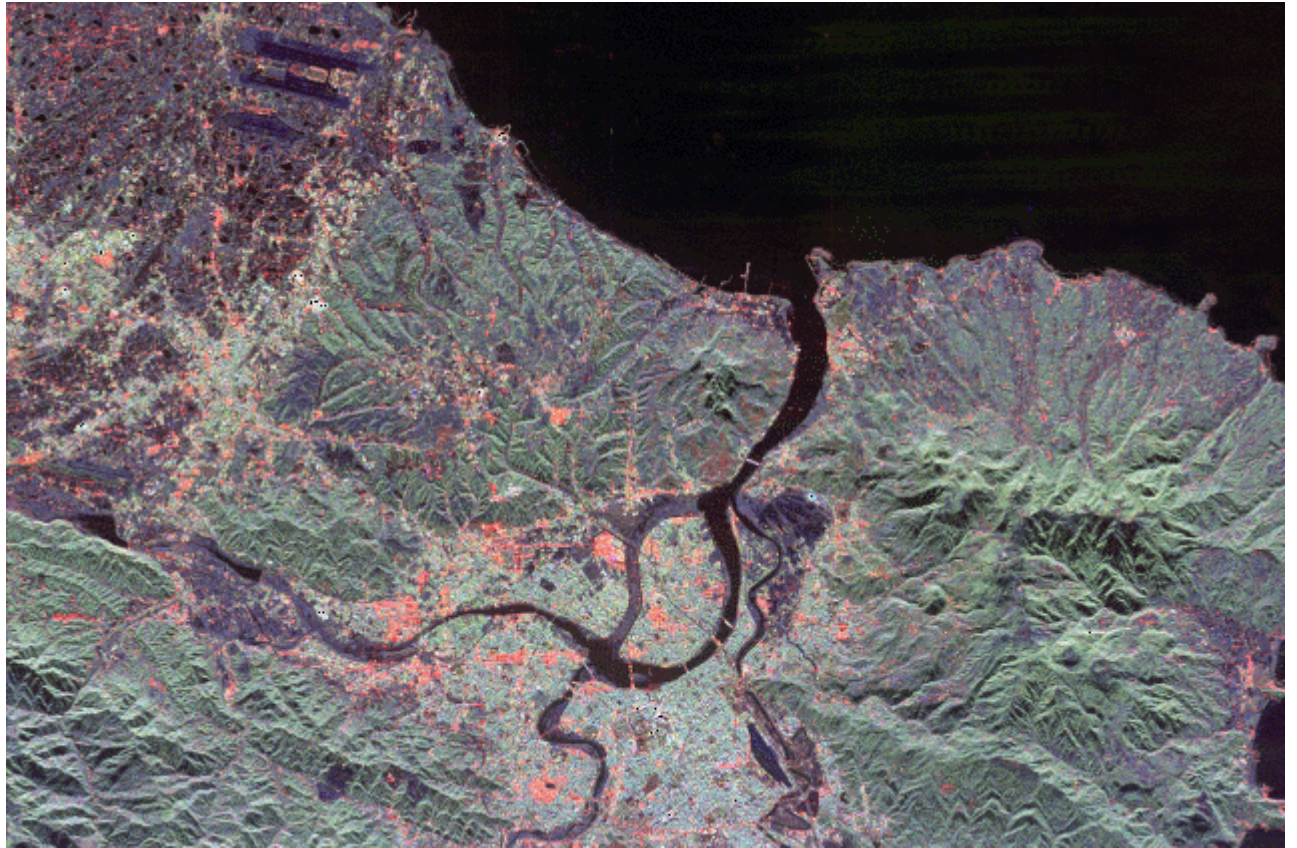

Taiwan 21st
century



Library as
collection of
“objects”

Spine label
with
LC Call
Number

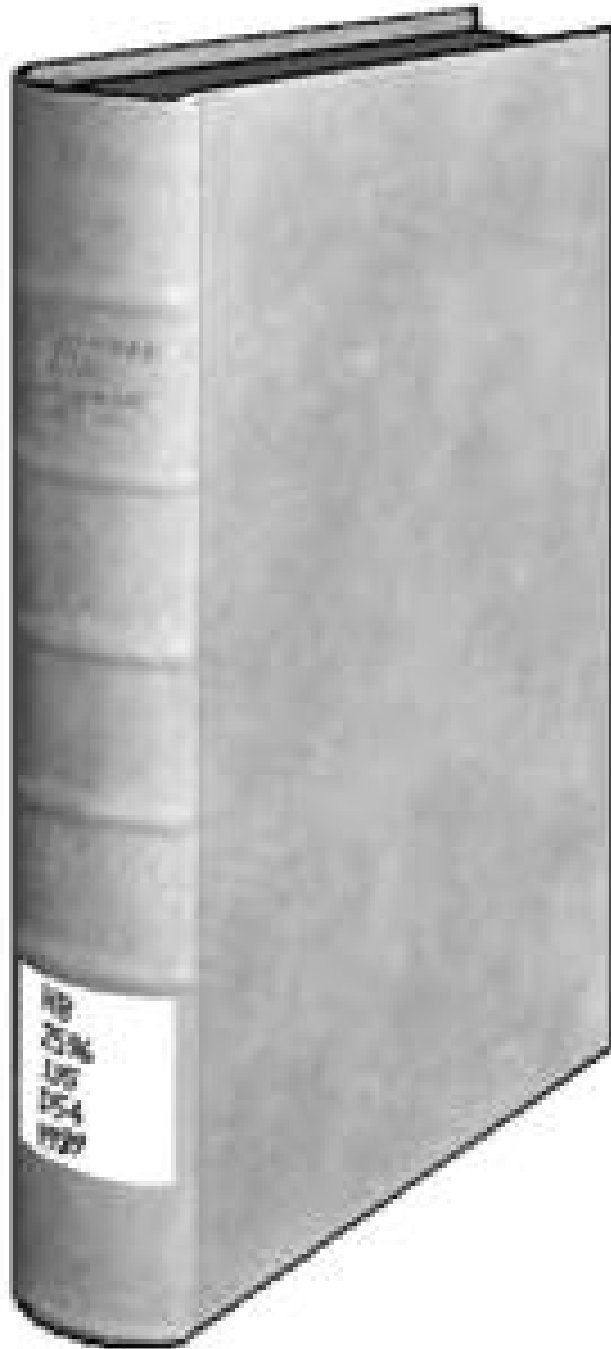

Book in codex
format with
metadata

Photo as Event

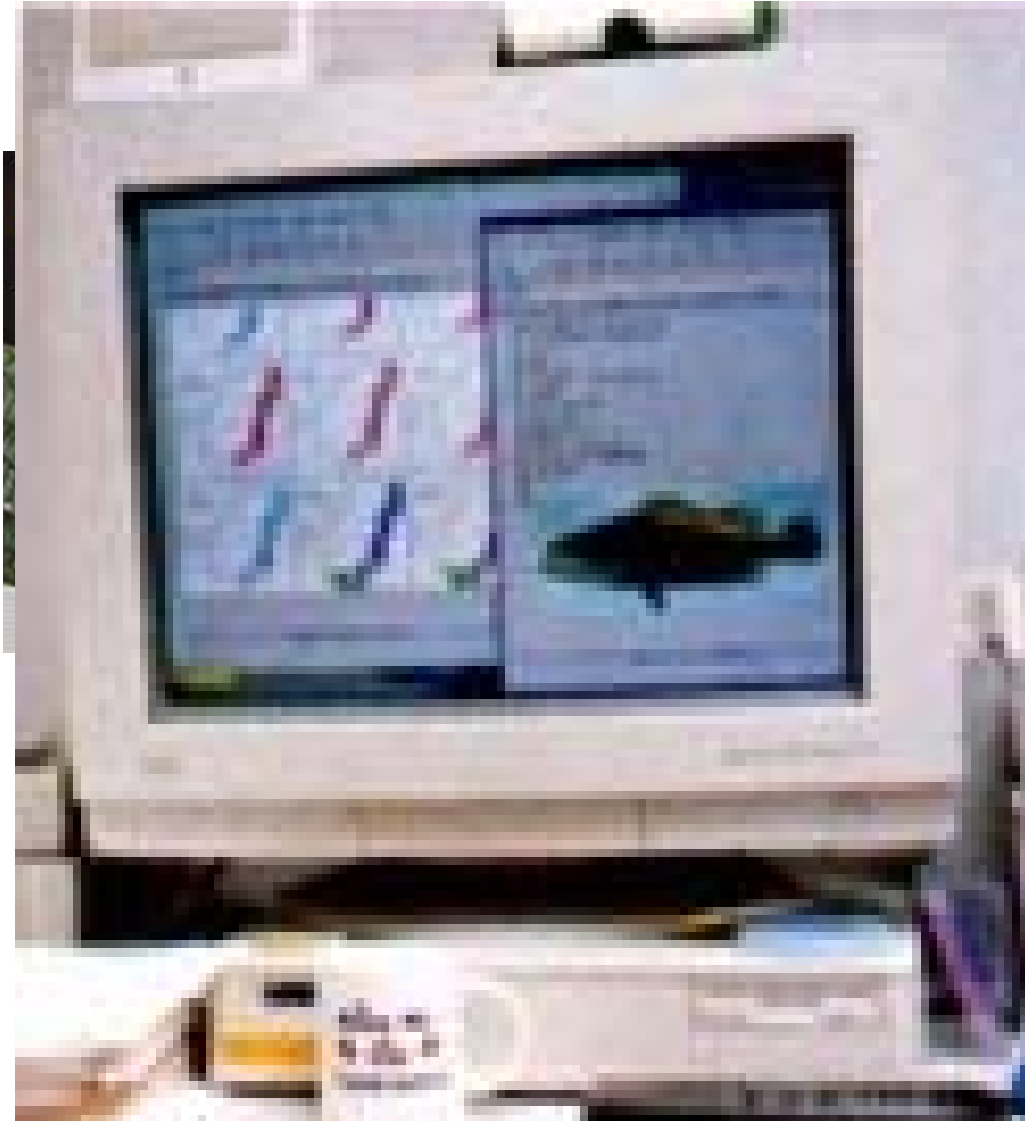



```
<Record  
  vol="T09"  
  title="n262"  
  page="p0019"  
  col="a08"  
  char="U+4F5B" />  
(MetaData)
```

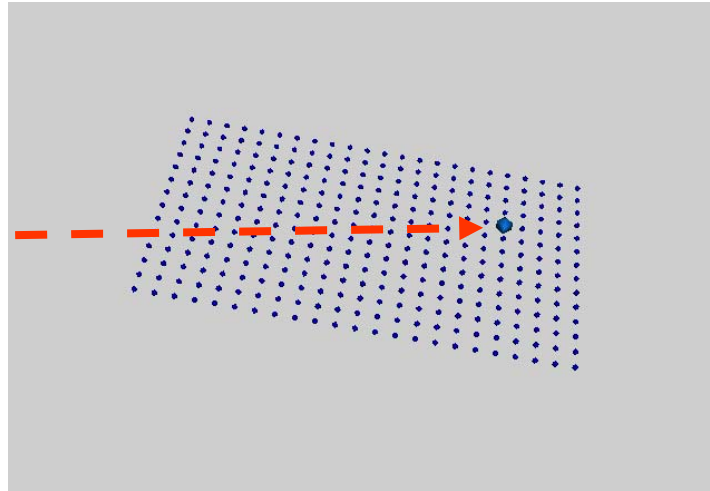
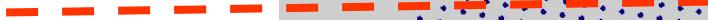

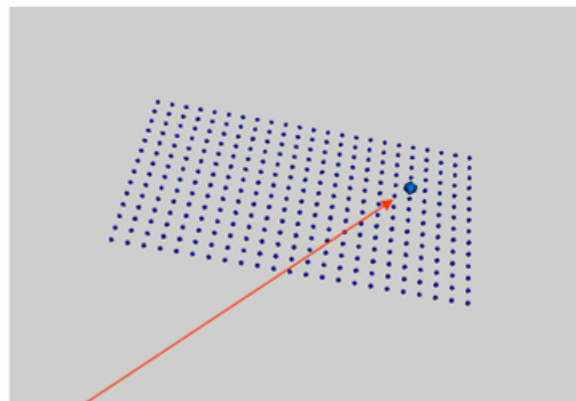
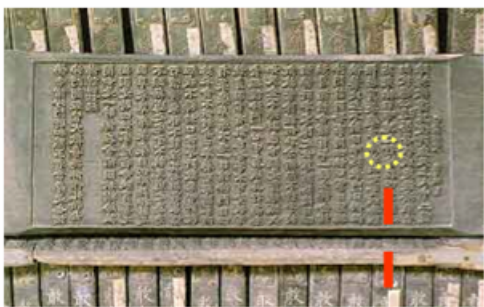

<Record
code="T09_n0262_p0019a08"
char="U+4F5B" />

Files 411-458

K 549 (XIV:49) (T. 1509)

- (i) Mahāprajñāpāramitāsūtra
- (ii) Za chieh tu lun (100 chüan) (Nāgārjuna)
- 大智度論
- 대지도론

Translation by Kumārajīva; begun in the summer of the 4th year of Hsiang Shih (弘始) and completed on the 27th day, 12th month, 7th year of Hsiang Shih (弘始), Later Ch'in dynasty (後秦) (A.D. 402-February 1st A.D. 406) in Hsiao-yao Garden (逍遙園).²

- (1) of K.3.
- (2) Cases 作-正 207-216; carved A.D. 1240-1242.
- (3) KDDK. 14:374-1379.
- (4) Nj. 1169; Ono 7:368d.

1. Vol. 431 ch. 1-3 序; Vol. 432 ch. 4-7 序; Vol. 433 ch. 8-10 序; Vol. 434 ch. 11-13 論; Vol. 435 ch. 14-17 論; Vol. 436 ch. 18-20 論; Vol. 437 ch. 21-24 論; Vol. 438 ch. 25-27 論; Vol. 439 ch. 28-30 論; Vol. 440 ch. 31-33 論; Vol. 441 ch. 34-36 論; Vol. 442 ch. 37-40 論; Vol. 443 ch. 41-44 經; Vol. 444 ch. 45-47 經; Vol. 445 ch. 48-50 經; Vol. 446 ch. 51-55 立; Vol. 447 ch. 56-60 立; Vol. 448 ch. 61-63 形; Vol. 449 ch. 64-67 形; Vol. 450 ch. 68-70 形; Vol. 451 ch. 71-73 論; Vol. 452 ch. 74-76 論; Vol. 453 ch. 75-80 論; Vol. 454 ch. 81-84 論; Vol. 455 ch. 85-87 論; Vol. 456 ch. 88-90 論; Vol. 457 ch. 91-95 正; Vol. 458 ch. 96-100 正.

2. T. 2154-213a.4.

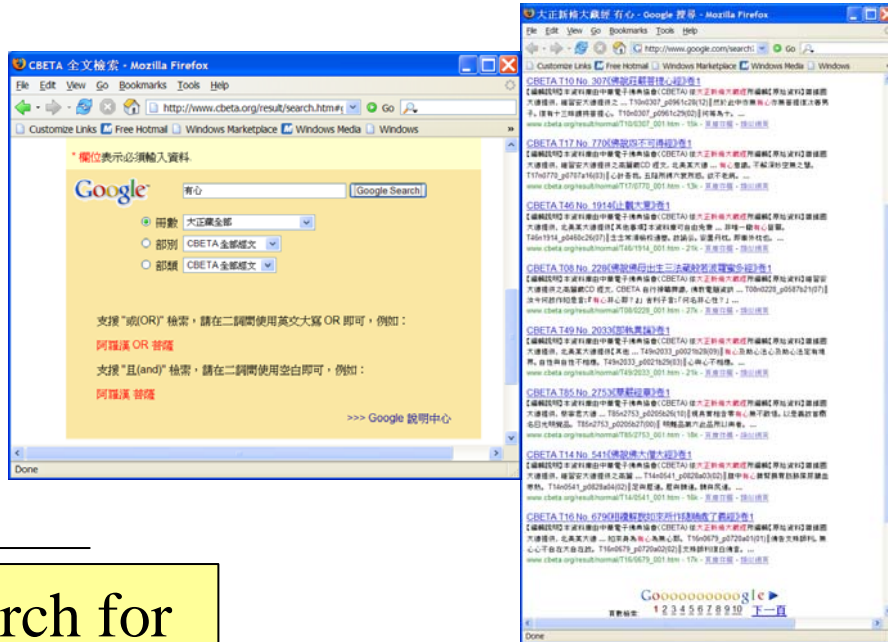

Google Search for target words in full text database



Normal Google search compared with a pattern search in surrogate imagery

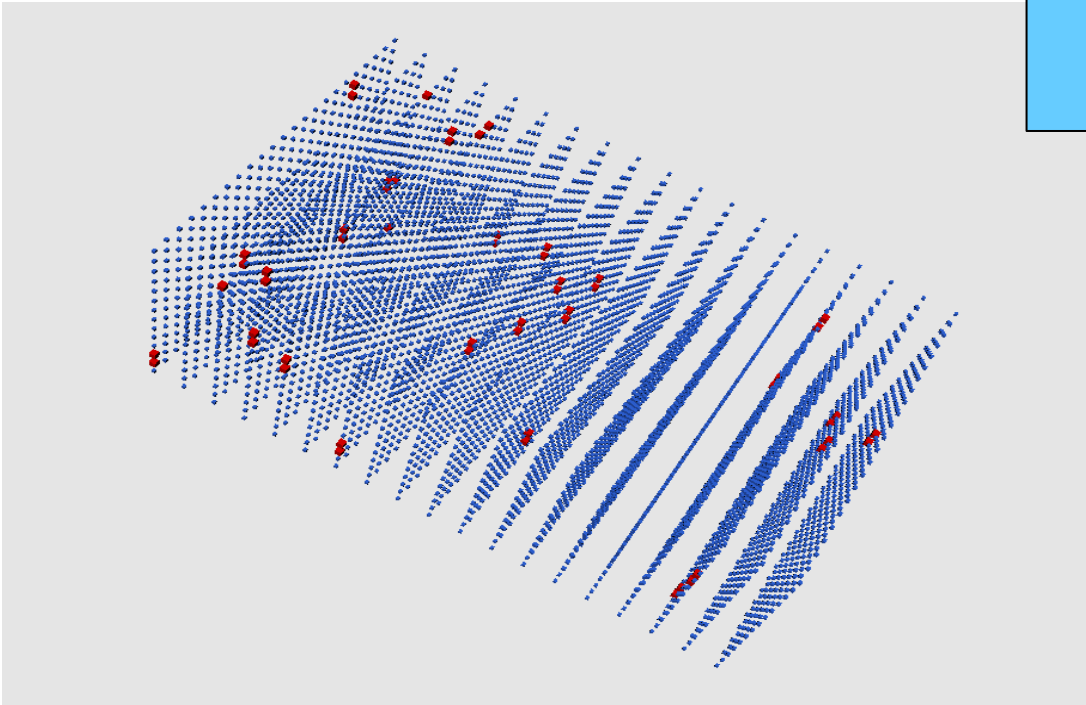

Pattern search by
translator and time

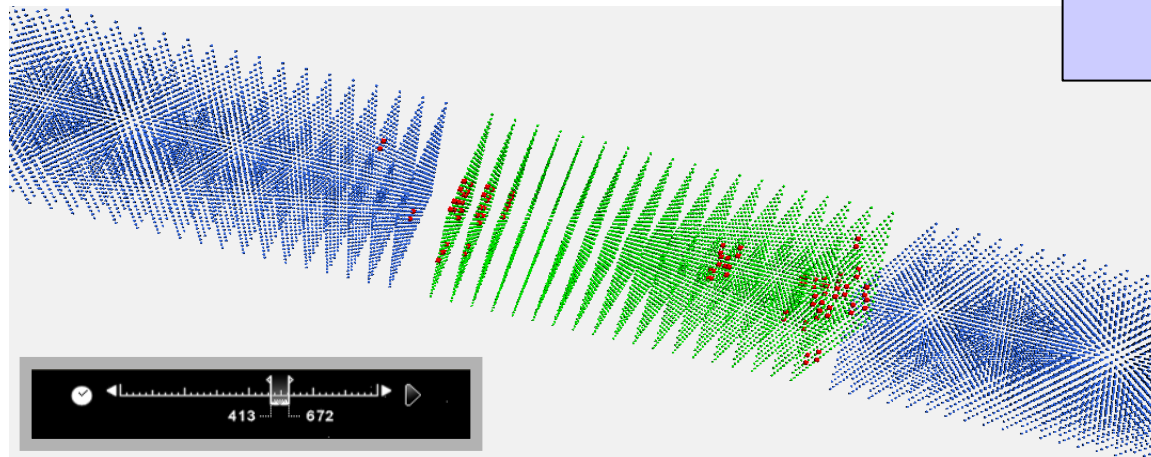

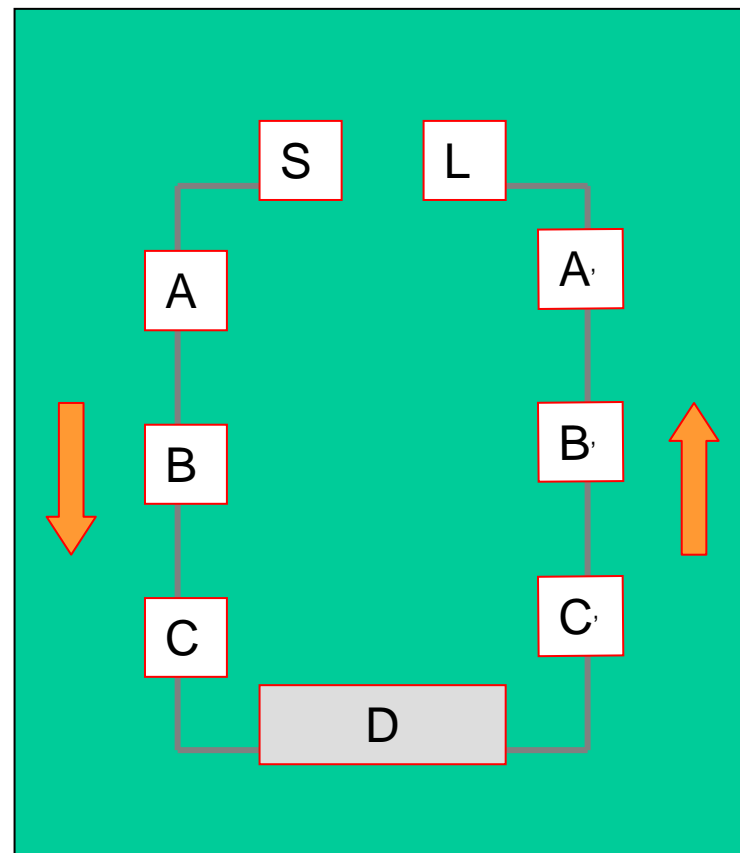
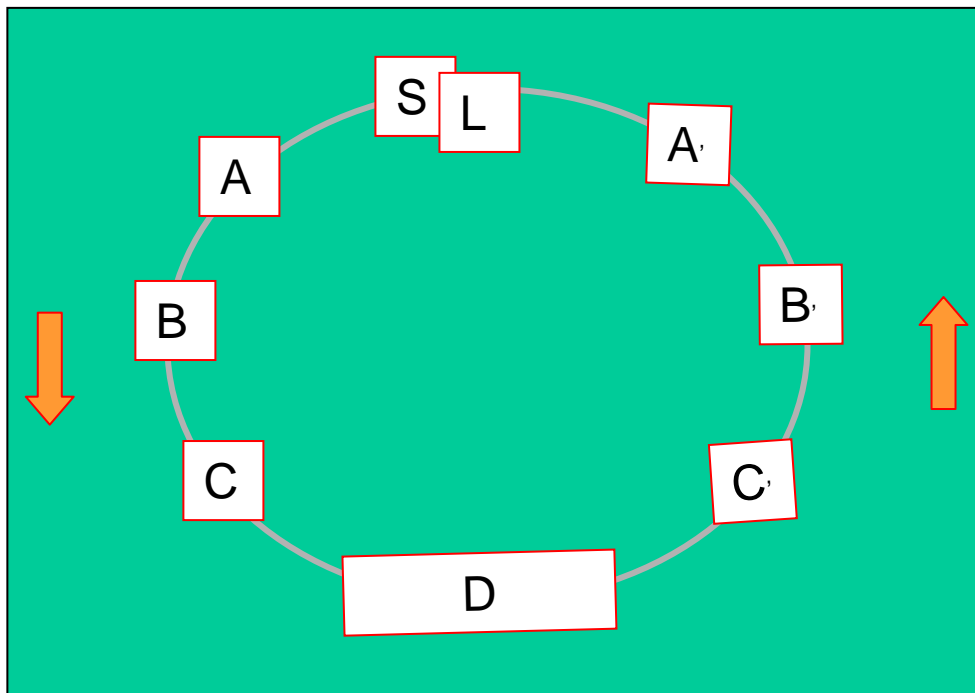

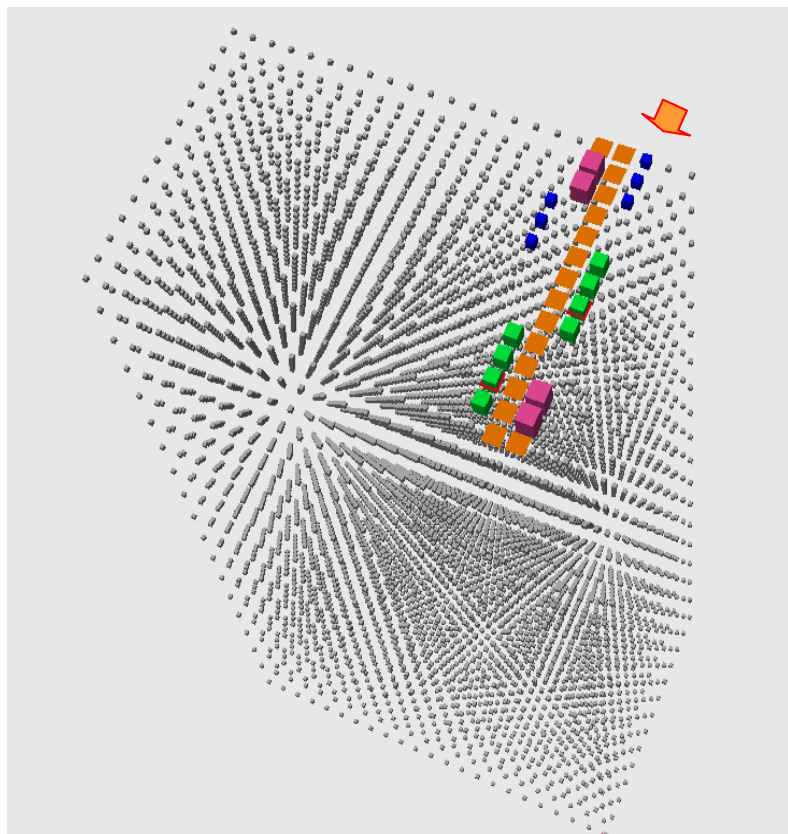

殊於變異。翻異二相故。與兩不同故。二德是
 能作。異此三德故是故非作者。外曰。若非作
 者用此何為。答曰。為立證義故。我證義成立。
 我是知者故。餘法不如是。獨存者。若異性
 及變異清淨故獨存。中直者。與三德異故。三
 德申縮不同故。是故為中直。譬如一道人獨
 住於一所。不隨他去來。唯見他來去。如是三
 德者。能申縮生死。唯有一我人。能見如是事。
 是故為中直。異性變異故。

前兩偈中說我者異自性亦

A sample Ring Composition in full text and in surrogate pattern format

